



ENGINEERING STUDIES SAMPLE EXAMINATION

Section 7 of the *New WACE Manual: General Information 2006–2009* outlines the policy on WACE examinations.

Further information about the WACE Examinations policy can be accessed from the Curriculum Council website at http://newwace.curriculum.wa.edu.au/pages/about_wace_manual.asp.

The purpose for providing a sample examination is to provide teachers with an example of how the course will be examined. Further finetuning will be made to this sample in 2007 by the examination panel following consultation with teachers, measurement specialists and advice from the Assessment, Review and Moderation (ARM) panel.



WACE Examination 2007

Question Paper

ENGINEERING STUDIES

Please place your student identification label in this box

Student Number: In figures

--	--	--	--	--	--	--	--

In words

Time allowed for this paper

Reading time before commencing work: Ten minutes

Working time for paper: Three hours

Material required/recommended for this paper

To be provided by the supervisor

This Question Paper

Standard Answer Booklet

Document Booklet

Engineering Studies Data Booklet

To be provided by the candidate

Standard items: Pens, pencils, eraser or correction fluid, ruler, highlighter, printed English language dictionary and/or bilingual dictionary (non electronic and not a thesaurus)

Special items: Appropriate plotting and measuring instruments and calculators satisfying the conditions set by the Curriculum Council for this course.

Important note to candidates

No other items may be taken into the examination room. It is your responsibility to ensure that you do not have any unauthorised notes or other items of a non-personal nature in the examination room. If you have any unauthorised material with you, hand it to the supervisor before reading any further.

Structure of this paper

Section	Outcomes	Suggested working time	Number of questions available	Number of questions to be attempted
SECTION A	Outcome 1 and Outcome 4	90 minutes	13	13
SECTION B Part I OR	Outcome 2 and Outcome 3	90 minutes	12 OR	12 OR
SECTION B Part II OR	Outcome 2 and Outcome 3		10 OR	10 OR
SECTION B Part III	Outcome 2 and Outcome 3		9	9

Instructions to candidates

- The rules for the conduct of Curriculum Council examinations are detailed in the *Student Information Handbook*. Sitting this examination implies that you agree to abide by these rules.
- Write your answers in the Standard Answer Booklet provided according to the following instructions:

SECTION A Answer all questions in Section A. A blue or black ball point or ink pen should be used. Reference should be made to the Data Booklet, where appropriate.

Where appropriate, use sketches to illustrate your answer. Do not sketch in ink. All dimensions are to be shown in millimetres.

SECTION B Section B has three parts. Choose questions to answer from **one part only**. Show all workings. Where appropriate, reference should be made to the Data Booklet. Round any calculations to 2 significant figures.

Section A: Core Engineering

This section has **THIRTEEN** questions. Answer **ALL** questions and **ALL PARTS** of questions in this section.

Allow approximately 90 minutes for this section *[90 marks]*.

Use the drawings in Section A, Part 1 of the Document Booklet to answer Questions 1 and 2.

Question 1

Look at the elevation and end elevation of the bracket shown in the drawings.
The total height of the bracket is

[1 mark]

- (A) 174
- (B) 184
- (C) 182
- (D) 158

Question 2

Look at the elevation and end elevation of the bracket shown in the drawings.
The total length of the bracket is

[1 mark]

- (A) 172
- (B) 170
- (C) 174
- (D) 182

Question 3

Sketch an appropriate view of section A-A showing the boss and flange detail.

[9 marks]

Use the information below to answer Questions 4 and 5

The bracket is designed to be supported under an extended workbench and provide support to one end of an axle. An opposite bracket will provide support to the other end of the axle. The axle is designed to support a roller used to tension a conveyor belt.

The bracket features a boss supporting a flange with a hole of $\text{Ø}24$ bored through to support the axle of the same diameter.

The bracket is likely to be manufactured from steel by a local firm specialising in steel casting

Question 4

Explain the differences there would be between the brackets for each end of the axle.

[2 marks]

SEE NEXT PAGE

Question 5

The manufactured brackets need to be couriered to your workplace in small crates, two to a box i.e. one bracket for each end of the axle.

To ensure minimal space and volume is utilised, explain what the minimum internal dimensions of the crate would be? Use diagrams where necessary to explain your answer.

[10 marks]

Use the information below to answer Questions 6 - 9

The Australian/New Zealand Standard on the safety of toys requires that ride-on toys are subjected to tests for stability and overload. The relevant sections of the Standard are provided in Section A, Part 2 of the Document Booklet.

You have been engaged to carry out a series of tests to determine whether a toy pedal car meets the requirements of the Standard. The pedal car will be marketed as a toy for children from the age of 2½ years upwards.

Question 6

For the stability tests, what load will the car have to carry?

[1 mark]

- (A) 25 kg
- (B) 50 kg
- (C) a child
- (D) 80 kg

Question 7

How many separate tests would be required to cover the requirements of the fore and aft stability tests?

[5 marks]

Question 8

Sketch a design for apparatus suitable for carrying out stability testing and brake testing procedures required by the Standard on the pedal car. Justify the choice of materials you would use to realise your design. Show the necessary systems and mechanisms you would employ in your design, including all adjustment systems.

[10 marks]

Use the information below to answer Questions 9 - 12

During prolonged hot weather, the electricity grid supplies the citizens of the metropolitan region and south west of WA with 3 600 MW of electricity during the late afternoon peak. Roughly 26.5% of this load is used to power air-conditioning systems. This proportion is predicted to rise to over 29% in the next five years, during which time the peak load is expected to rise to 4200 MW.

Question 9

Explain how the design and use of buildings could be improved to reduce the dependence on air-conditioning.

[8 marks]

Question 10

If improvements to building design could reduce air conditioner use by 10% over the next 5 years, estimate the reduction in CO₂ production that would result. (1 kWh of electricity used produces approximately 1 kg of CO₂.) State all your assumptions clearly and where you might be under- or over-estimating.

[14 marks]

Question 11

Three types of power stations: coal fired, nuclear and a wind farm are used. Compare and contrast these **THREE** power station types on the basis for:

- (i) providing cheap energy
- (ii) effects on global warming
- (iii) environmental pollution.

[12 marks]

Question 12

Describe the energy life cycle components of each type of power station and their inter-connections. Provide suitable diagrams to illustrate your answer to show where the energy system flow interacts with the environment.

[12 marks]

Question 13

A school student uses a cordless electric drill battery and motor as a primary power plant for a robotic vehicle. The 18v battery is rated at 2.4 Amp Hours at an unloaded 1000rpm. Give the instant power, in Watts, that the drill will give out.

[5 marks]

END OF SECTION A

THIS PAGE HAS BEEN LEFT BLANK INTENTIONALLY

SEE NEXT PAGE

Section B

This section has **THREE** parts. Candidates are to choose ONE part only and answer ALL questions in that part.

Part I: Electrical/Electronic systems

Part II: Materials, structures and mechanical systems

Part III: Systems and control.

Allow approximately 90 minutes for this section [*100 marks*].

Section B - Part I: Electrical/Electronic Systems

This part has **TWELVE** questions. Answer **ALL** questions. Write all answers in the standard answer booklet. Show all workings.

Allow approximately 90 minutes for this section [100 marks].

Question 1

Capacitance is a measure of?

[1 mark]

- (A) the amount of resistance in a capacitor
- (B) the amount of electrical energy stored in a capacitor
- (C) the maximum voltage load of a capacitor
- (D) the rate of current discharging from a capacitor

Question 2

The most common voltage used in Australian homes is?

[1 mark]

- (A) 440 AC
- (B) 240 DC
- (C) 240 AC
- (D) 240 BC

Question 3

There are three main factors that affect the capacitance of capacitors. Which of the following is **not** a factor?

[1 mark]

- (A) the cross-sectional area of the plates
- (B) the distance between the plates
- (C) the type of dielectric material used
- (D) the thickness of the dielectric material

Question 4

Which of the following components is **not** a semi-conductor?

[1 mark]

- (A) transistor
- (B) resistor
- (C) diode
- (D) silicon controlled rectifier

Question 5

A resistor is normally placed in series with a light emitting diode (LED) to:

[1 mark]

- (A) decrease the capacitance of the diode
- (B) limit the amount of current passed through the diode
- (C) reduce the voltage applied across the diode
- (D) control the brightness of the diode.

Question 6

Briefly describe the difference between conventional current flow and electron current flow in electronic circuits.

[3 marks]

Question 7

Consider the circuit diagram below.

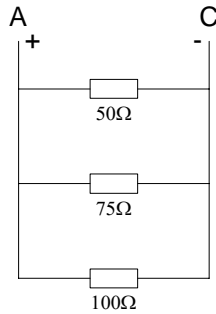

(a) Explain why the current flowing through each resistor will not be the same.

[4 marks]

(b) Calculate the total resistance between nodes A and C.

[4 marks]

Question 8

Apricot Laptop Computer company has asked you to describe the basic design and construction of a step-down transformer with a 240VAC input voltage and a 24VAC output.

(a) Describe the principles of operation that will be used in the design of the transformer.

[6 marks]

(b) Sketch and annotate a drawing indicating the components of the transformer to assist your explanation.

[5 marks]

Question 9

A 24VDC electric motor draws 40 amps of current under normal operational conditions.

Calculate the energy used in for a two hour period of operation in:

- Joules
- Kilowatt hours.

[8 marks]

Question 10

Consider the two wave forms in the diagram below.

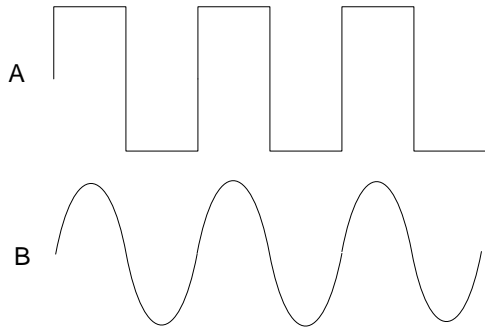

(a) Identify the analogue and digital waveforms.

[2 marks]

(b) Explain the difference between an analogue and digital system. Use the above waveforms to assist your answer.

[4 marks]

(c) Identify and briefly explain a practical application of a digital and an analogue system.

[4 marks]

Question 11

An engineer for a security company has been given the task of redesigning a light sensing device. The existing circuit is shown below. In this design the LED lights when the LDR is exposed to light.

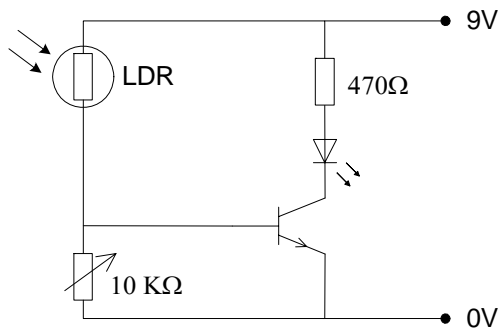

(a) Explain how the existing circuit works.

[7 marks]

(b) Explain the role of the 10 kΩ variable resistor.

[2 marks]

(c) Draw a redesigned circuit so the LED lights when the LDR receives no light, and is off when there is light falling on the LDR.

[7 marks]

(d) Explain how the redesigned circuit operates.

[8 marks]

- (e) The new design is intended to control a set of garden lights that will switch on every day during the hours of darkness. Describe what additional factors would need to be considered to build this device.

[4 marks]

- (f) Describe what operational and safety issues should be considered before the design is complete, manufacture starts and any products are sold.

[3 marks]

Question 12

The circuit shown for Question 11. was a low voltage, low current application. It reacts sluggishly to movements in temperature and does not turn its output on or off sharply.

Design a different version/type of circuit that is more sensitive when detecting changes in temperature AND can be used to control a 240 V AC overhead cooling fan for a small office.

- include all component names, types and values in your solution
- provide a full explanation of how the circuit(s) function in terms of inputs, process and outputs, referring to current, voltage and amperage where necessary.
- include all necessary calculations to justify component choice and annotate the diagram to explain its key features.

[24 marks]

THIS PAGE HAS BEEN LEFT BLANK INTENTIONALLY

SEE NEXT PAGE

Section B: Part II – Materials, structures and mechanical systems

This part has **TEN** questions. Attempt **ALL** questions. Write all answers in the standard answer booklet. Show all workings.

Allow approximately 90 minutes for this section [100 marks].

Question 1

The linkage mechanism shown below is in equilibrium. The relative length of the two arms is 2:1.

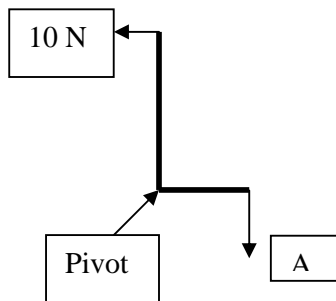

The force A is equal to:

[1 mark]

- (A) 5 N
- (B) 15 N
- (C) 20 N
- (D) 30 N

Question 2

A steam engine burns coal, which liberates 83.4 kJ of energy in the furnace per second; the steam engine provides 5 KW of useful power. The efficiency of the system is:

[1 mark]

- (A) 3.4%
- (B) 0.6%
- (C) 6.0%
- (D) 34.0%

Question 3

A ship with a mass of 25 000 tonnes is brought to rest from a velocity of 14 km/hr in 36 seconds. What force is required to achieve this?

[1 mark]

- (A) kN
- (B) 2.701 kJ
- (C) 2.701 MN
- (D) 1.350 MN

Question 4

The hardness of a material can be measured by:

[1 mark]

- (A) how much energy is absorbed during fracture
- (B) its ductility
- (C) an indentation test
- (D) measuring elongation when stress is applied

Question 5

Which of the following materials has an Elastic (Young's) Modulus of 100 KN/mm^2 ?

[1 mark]

- (A) steel
- (B) brass
- (C) aluminium
- (D) cast iron

The information below relates to question 6.

A windmill used for generating electricity can have the generator in two positions. In option 1, the generator can be located at the top connected directly to the rotating vanes. In option 2, the generator can be at ground level connected by shafts and gears to the rotating vanes.

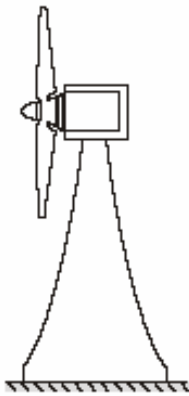

Option 1

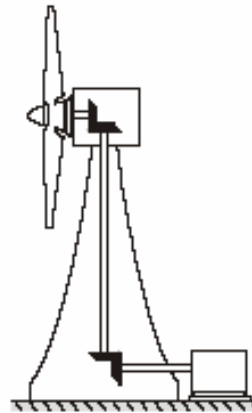

Option 2

(Learning and Teaching Scotland, 1999)

Question 6

- (a) Sketch a block diagram showing the energy and motion conversions, and energy conversions through the system.

[14 marks]

- (b) The system shown in option 2 does not produce as much electricity as the system shown in option 1. Explain and compare the energy effectiveness of the TWO options.

[4 marks]

Question 7

(Scottish Qualifications Authority, n.d.)

The load/Eject table of the CD Rom drive for a computer is driven open by a motor which runs at 600 rev/min. Details of the operating mechanism are shown below.

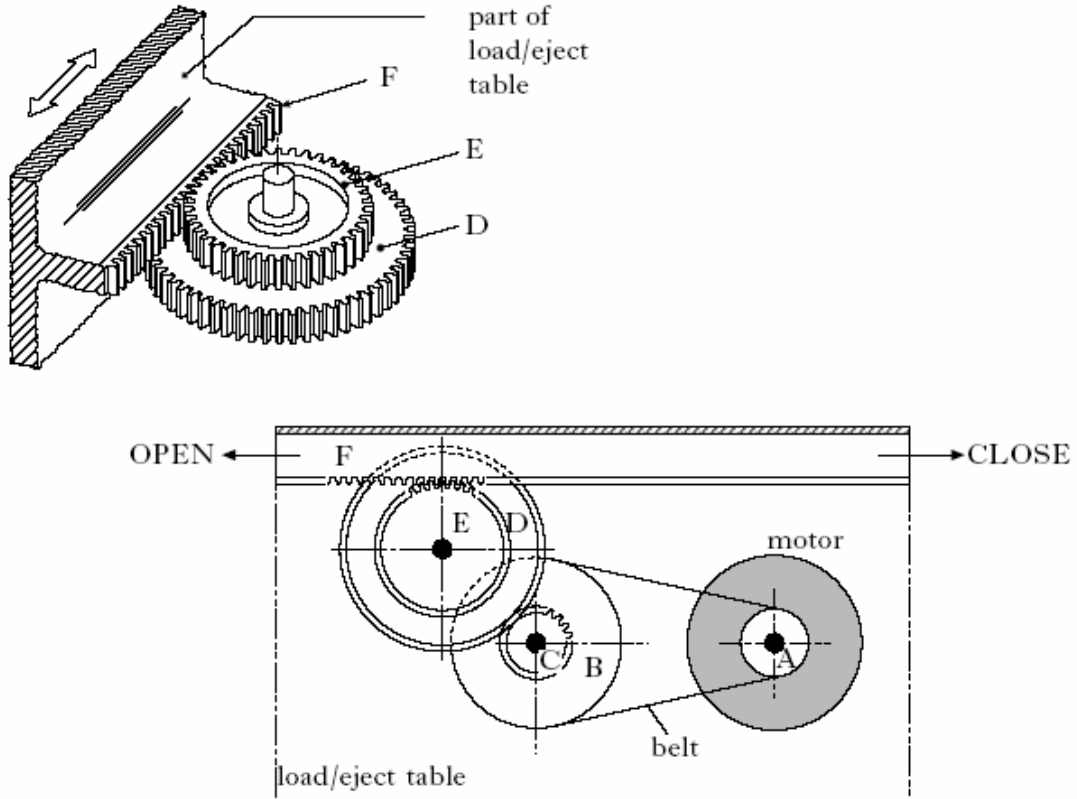

Pulley A	10 mm diameter	Gear C	20 teeth
Pulley B	25 mm diameter	Gear D	60 teeth
		Gear E	40 teeth

Component F is attached to the load/eject table and is driven by gear E to open and close the table.

(a) Name the mechanism made up of components E and F

[1 mark]

(b). Calculate the speed of gear E, giving your answer in revolutions per second

[6 marks]

Question 8

The graph below shows the stress-strain graph as a result of a tensile test on a specimen of a certain material.

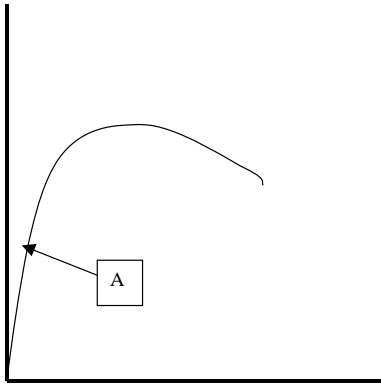

(a) Redraw the graph in the standard answer booklet and label each axis with the appropriate name.

[1 mark]

(b) Indicate the following regions or points on the diagram:

- elastic deformation
- plastic deformation
- elastic limit
- ultimate tensile stress.

[4 marks]

(c) Indicate on the graph the energy absorbed during the tensile test.

[4 marks]

(d) Give any evidence of strain hardening in this test.

[3 marks]

(e) Explain whether the material is ductile or brittle.

[6 marks]

(f) Calculate the Elastic (Young's) Modulus of the material if the point marked A corresponds to values on the y and x axes of 25 MPa and 0.00025 respectively.

[3 marks]

(g) Give the units for the Elastic Modulus.

[1 mark]

Question 9

The following stress-strain graph was prepared by a lab assistant.

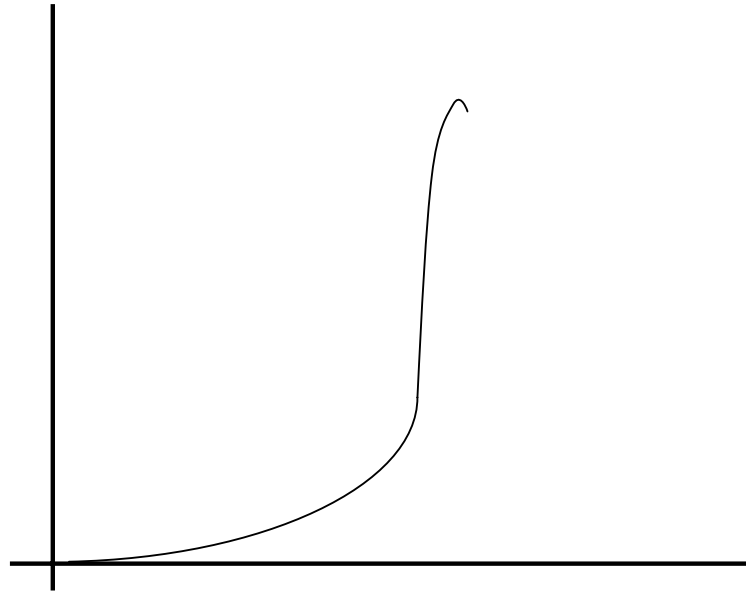

- (a) Explain the physical properties suggested by this graph and extrapolate a set of conditions that may have given rise to this graph. *[10 marks]*
- (b) Explain the difference between a load-deformation graph and a stress-strain graph. *[6 marks]*
- (c) Explain why knowledge of the stress-strain properties of a material is considered important in the use of that material in the manufacture and use of a product. *[4 marks]*

Question 10

An electrician and her assistant are carrying a ladder which is 4 m long, has a mass of 20 kg, and has its centre of gravity 1.5 m from one end. A toolbox with a mass of 15 kg is slung from the mid-point of the ladder.

- (a) Sketch a free body diagram of the ladder being carried. *[3 marks]*
- (b) If the electrician is supporting the lighter end, where must the apprentice be if he/she is supporting a load of 216 N? *[7 marks]*
- (c) Sketch an accurate bending moment diagram of the ladder, labelling all the principle values. *[20 marks]*

THIS PAGE HAS BEEN LEFT BLANK INTENTIONALLY

SEE NEXT PAGE

Section B: Part III - Systems and Control

This part has **NINE** questions. Attempt **ALL** questions. Write all answers in the standard answer booklet. Show all workings.

Allow approximately 90 minutes for this section [100 marks].

Question 1

The diagram to the right shows a Logic symbol.
What is this logic symbol called?



[1 mark]

- (A) Not
- (B) Nand
- (C) Nor
- (D) And

Question 2

An EEPROM is a type of electronic microchip. Which of the following statements describes its main advantage?

[1 mark]

- (A) reliable and cheap
- (B) erasable and programmable
- (C) electronic and robust
- (D) electrostatically positive

Question 3

Which one of the following devices is **not** a sensor device?

[1 mark]

- (A) light dependent resistor
- (B) relay
- (C) microphone
- (D) thermistor

Question 4

The term **feedback** is usually associated with which type of control system?

[1 mark]

- (A) open loop
- (B) wiring loop
- (C) manual loop
- (D) closed loop

Question 5

A CNC lathe is used to manufacture components for a small toy. What do the initials CNC stand for?

[1 mark]

- (A) control next component
- (B) computer numerical control
- (C) computer number console
- (D) control numbered computer

Question 6

The drill press shown below must not start until the pulley guard is firmly down (which closes a **micro switch**) and the **start** button is pressed.

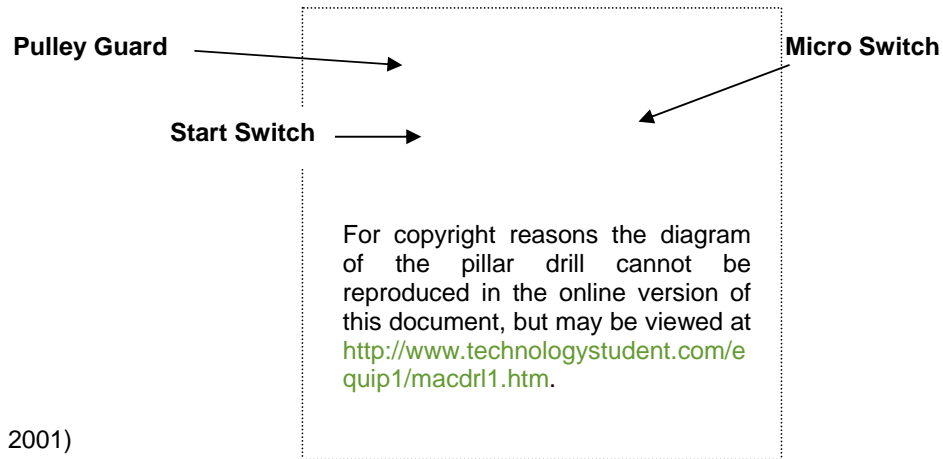

(Ryan, 2001)

(a) Complete the truth table for this drill using the table headings:

Micro switch	Start switch	Motor

[4 marks]

(b) Identify and draw the logic gate this table represents.

[2 marks]

(c) Two operations of the drill press that require logic controls to prevent unsafe operation are the foot pedal and chuck visor.

Suggest a suitable control system solution for one of these operations. Use a suitable diagram to explain how your solution will work.

[7 marks]

Question 7

A company is thinking of introducing robot arms to parts of its factory.

- (a) Explain why a *systems analysis* needs to be carried out before the robot arms are introduced.

[10 marks]

- (b) The company buys robots which have six *degrees of freedom*. What is meant by degrees of freedom?

[2 marks]

- (c) Draw or sketch a labelled diagram with anatomical names for each part of the robot, to illustrate your answer to part (c).

[6 marks]

- (d) Each robot has an analogue pressure sensor fitted to its gripper. Why is it necessary for the computer which controls the robots to have an analogue to digital converter?

[2 marks]

Question 8

A section of road is being resurfaced. Temporary traffic lights are being used to control the traffic. Drivers are stopped at the lights, as shown below. They can see there are no cars coming the other way, but still have to wait a long time for the lights to change.

For copyright reasons the photograph of the temporary traffic lights cannot be reproduced in the online version of this document, but may be viewed at <http://www.bbc.co.uk/wales/mid/sites/travel/pages/road.shtml>.

(BBC, n.d.)

- (a) In this situation, is it more likely that the traffic lights are controlled by an open or a closed loop system? Give a reason for your answer.

[2 marks]

- (b) Describe how the use of sensors could improve the traffic flow.

[2 marks]

- (c) Suggest a suitable type of sensor for this situation and why it would be suitable and what input information it is intended to detect.

[2 marks]

- (d) The proposed traffic control system may fail if there is a very large vehicle that takes a very long time to traverse the road works. Discuss what implications this will have for the design of the lights control system.

[6 marks]

- (e) Propose a solution flow chart program to implement the above.

- Explain all conclusions drawn.
- Use diagrams and sketches to illustrate your answer.

[24 marks]

Question 9

You have been asked to design a small portable self-contained micro-controlled system to control the drip irrigation on a single large pot plant. Assume that a suitable water supply is locally available. The requirements are:

- The drip should turn on when the moisture content in the soil falls below a nominated level.
- The drip only operates on nominated days of the week to meet Waterwise regulations.
- The drip only works during hours of darkness.

- (a) Nominate the required components.

[6 marks]

- (b) Draw a systems diagram showing how the logic of the systems will operate.

[4 marks]

- (c) Draw a flow chart to explain the operation of the program in the microcontroller. Include all routines and sub routines, and reference to all components and interfacing.

[16 marks]

END OF PAPER

ACKNOWLEDGEMENTS

SECTION B: Part II

- Question 6:** Learning and Teaching Scotland. (1999). *DET: Technological Studies: Energy Intermediate 2: Support materials* (p. 12, figs 14a, 14b). Retrieved October, 2006, from http://www.ltscotland.org.uk/nq/images/4599det2_tcm4-124276.pdf.
- Question 7:** Scottish Qualifications Authority. (n.d.). *Intermediate 2 Technological Studies: Specimen question paper* (p. 15, q. 9). Retrieved October, 2006, from http://www.sqa.org.uk/files/nq/c03611_sqp.pdf.

SECTION B: Part III

- Question 6:** Ryan, V. (2001). *Workshop machinery—machine drills* (Pillar drill diagram). Retrieved October, 2006, from Technologystudent.com website: <http://www.technologystudent.com/equip1/macdr11.htm>.
- Question 8:** BBC. (n.d.). *Traffic & travel : Wales, mid* (Photograph of road signs). Retrieved October, 2006, from <http://www.bbc.co.uk/wales/mid/sites/travel/pages/road.shtml>.